



# UM6BG1TC

**ISUZU**

ISUZU MOTORS ENGINE SALES INC.

# UM6BG1TC

## DIMENSIONS (mm)

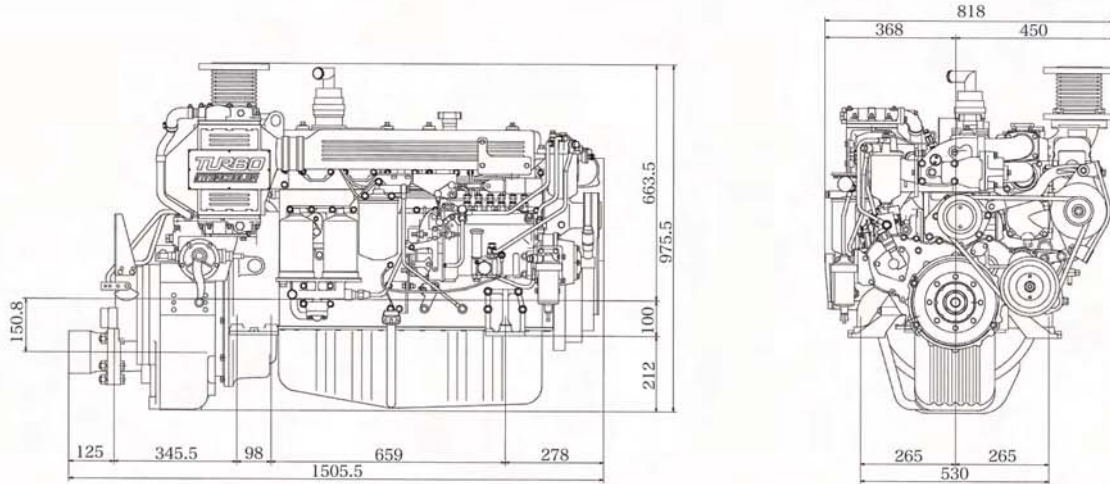

## PERFORMANCE CURVES

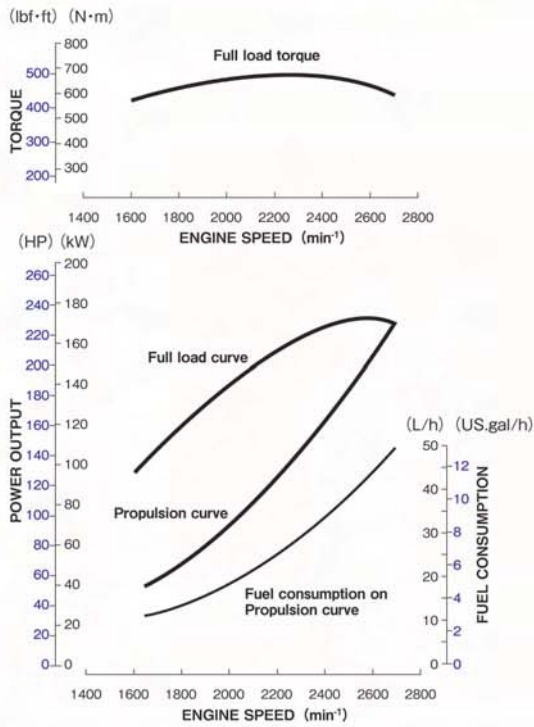

## ENGINE SPECIFICATIONS

Configuration		6-cylinder, vertical in-line, 4-cycle diesel engine	
Bore x Stroke		mm (in)	105 x 125 (4.13 x 4.92)
Displacement		Lit. (cid)	6.494 (396)
Rated output	kW(PS)/min <sup>-1</sup>	Medium duty	154 (210) / 2600
		Light duty	169 (230) / 2700
Application		Commercial use	
Governor type		Mechanical	
Combustion type		Direct injection	
Aspiration		Turbo charged / Intercooler	
Exhaust gas status		IMO Tier II	
Engine weight	kg (lb)	Engine	600 (1,323)
		with MGN40E	769 (1,695)
Fuel used		Diesel fuel	
Starter		V-kW	24 - 4.5
Alternator		V A	24 40
Lubrication method		Full flow pressure circulation	
Cooling method		Freshwater, full flow pressure circulation (Seawater, indirect)	
Heat exchanger (seawater circulation)		Multi-tube type (freshwater→seawater)	
Intercooler		Multi-tube type (seawater circulation)	
Rotation direction	Crankshaft	Right (clockwise) viewed from front of engine	
	Propeller shaft	Right (clockwise) viewed from stern	
Idling speed		min <sup>-1</sup>	500
Marine gear	Marine Gear Model	MGN40E	
	Clutch type	Wet, Multi-plate hydraulic type	
	Reverse type	Constant-mesh type gear	
	Reduction ratio	1.94, 2.33, 2.91, 3.45	

Specifications subject to change without notice

## ACCESSORIES

### Standard.....

- Installation kit
- Kingston valve
- Battery relay
- Extension harness (5m)
- Seawater pump impeller \*
- Bilge pump
- Control head
- Instrument panel
- Oil drain pump
- Blow-by pipe
- V-belt \*
- Tool kit
- Owner's manual

\* spare parts

### Option.....

- Extension harness (5m)
- Control cable (4m,6m,10m,12m)
- Stop cable (4m,6m,8m)



# ISUZU UM6BG1TC DIESEL ENGINE GEAR LESS

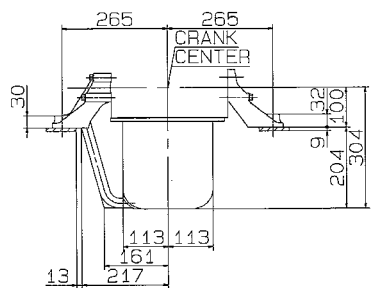

VIEW A

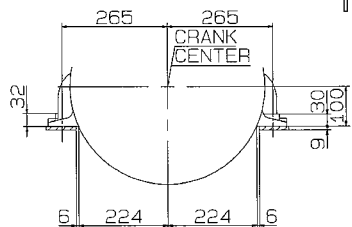

VIEW B

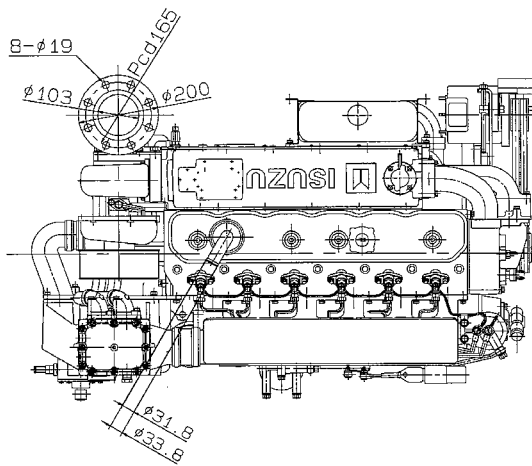

SEA WATER  
OUTLET

SEA WATER INLET  
12-M10x1.5 DEEP18  
12-M10x1.5 DEEP18  
18-M10x1.5

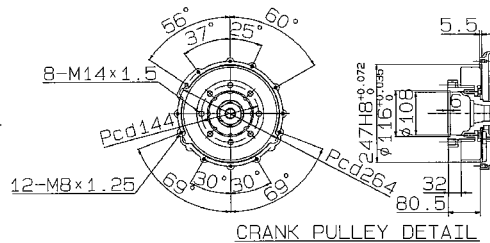
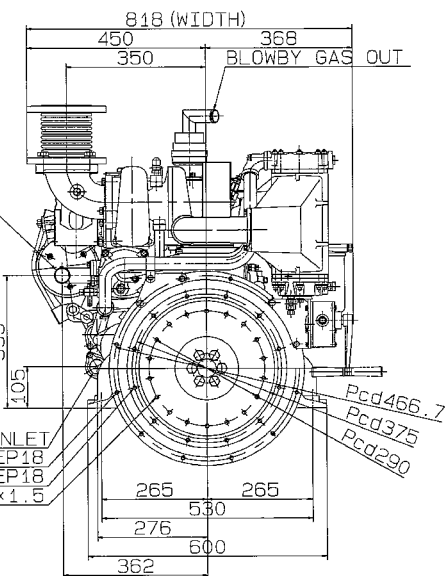

CRANK PULLEY DETAIL

SEA WATER INLET,  
OUTLET PIPE DETAIL

FUEL INLET, OUTLET  
PIPE DETAIL

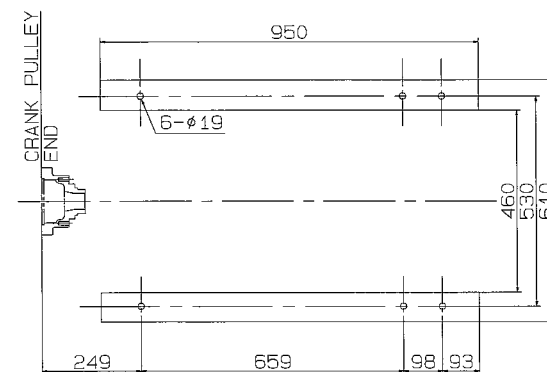

ENGINE MOUNTING

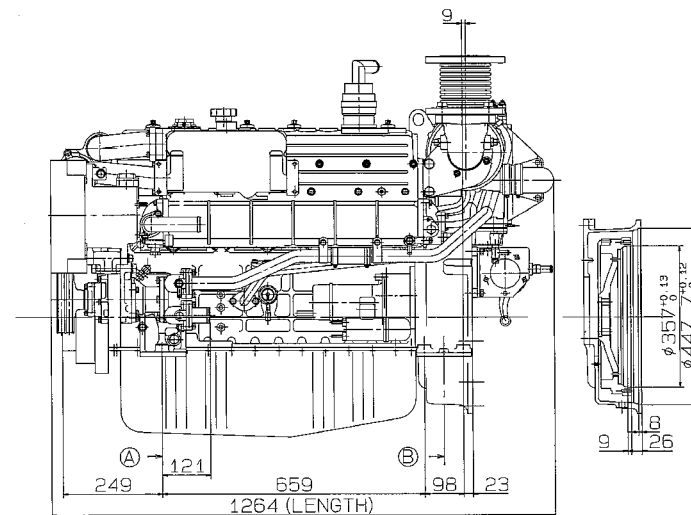
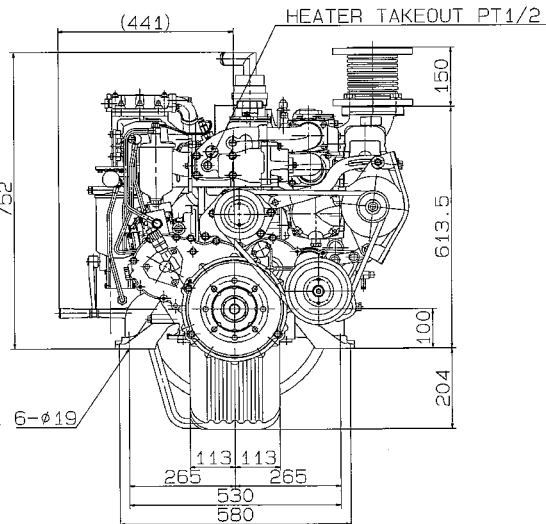
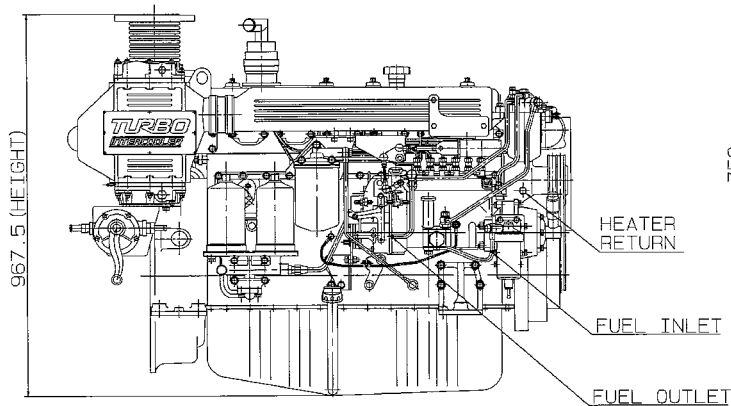

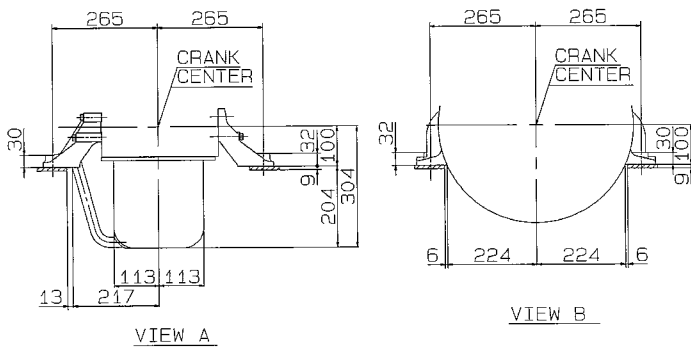

ISUZU UM6BG1TC DIESEL ENGINE  
MGN40E-1A

