

# UM4JG1TCX

**ISUZU**

ISUZU MOTORS ENGINE SALES INC.



# UM4JG1TCX

## DIMENSIONS (mm)

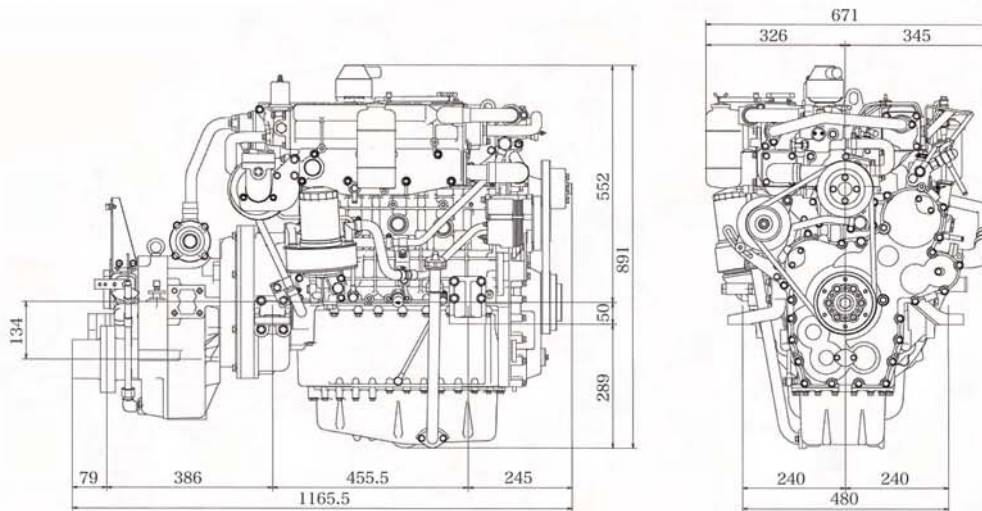

## PERFORMANCE CURVES

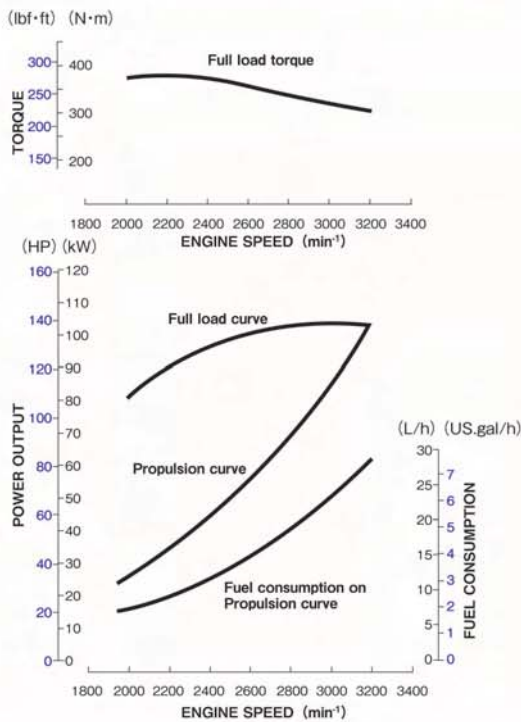

## ENGINE SPECIFICATIONS

Configuration	4-cylinder, vertical in-line, 4-cycle diesel engine		
Bore x Stroke	mm (in)	95.4 x 107 (3.75 x 4.21)	
Displacement	Lit. (cid)	3.059 (186)	
Rated output	kW(PS)/min <sup>-1</sup>	Medium duty	94 (128) / 3100
		Light duty	101 (138) / 3200
Application	Commercial use		
Governor type	Mechanical		
Combustion type	Direct injection		
Aspiration	Turbo charged / Intercooler		
Engine weight	kg (lb)	Engine	324 (714)
		with MGN30A	450 (992)
Fuel used	Diesel fuel		
Starter	V-kW	24 - 3.2	
Alternator	V-A	24 - 30	
Lubrication method	Full flow pressure circulation		
Cooling method	Freshwater, full flow pressure circulation (Seawater, indirect)		
Heat exchanger (seawater circulation)	Multi-tube type (freshwater→seawater)		
Intercooler	Multi tube type (seawater circulation)		
Rotation direction	Crankshaft	Right (clockwise) viewed from front of engine	
	Propeller shaft	Right (clockwise) viewed from stern	
Idling speed	min <sup>-1</sup>	500~550	
		Marine Gear Model	MGN30A
Marine gear	Clutch type	Wet, Multi-plate hydraulic type	
	Reverse type	Constant-mesh type gear	
	Reduction ratio	2.04, 2.52, 3.05, 3.44	

Specifications subject to change without notice

## ACCESSORIES

### Standard.....

- Installation kit
- Kingston valve
- Battery relay
- Extension harness (3m)
- Seawater pump impeller \*
- Bilge pump
- Control head
- Instrument panel
- Tool kit
- Owner's manual

\* spare parts

### Option.....

- Extension harness (3m)
- Control cable (4m,6m,10m,12m)
- Stop cable (4m,6m,8m)

## ISUZU MOTORS ENGINE SALES INC.

<http://www.isuzumarine.co.jp>

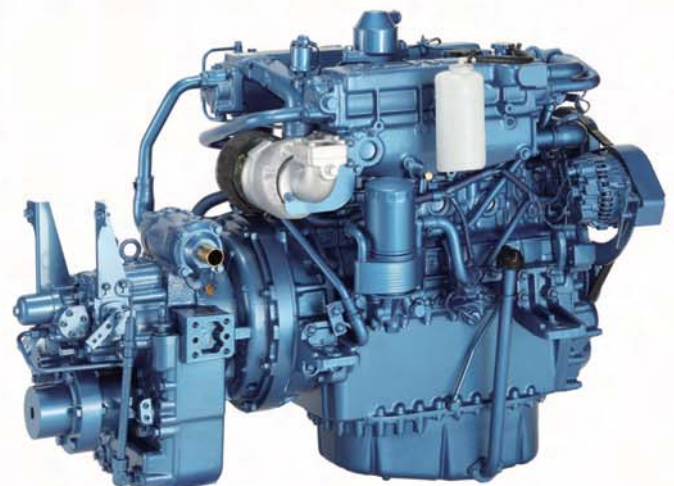

# ISUZU UM4JG1TCX DIESEL ENGINE GEAR LESS

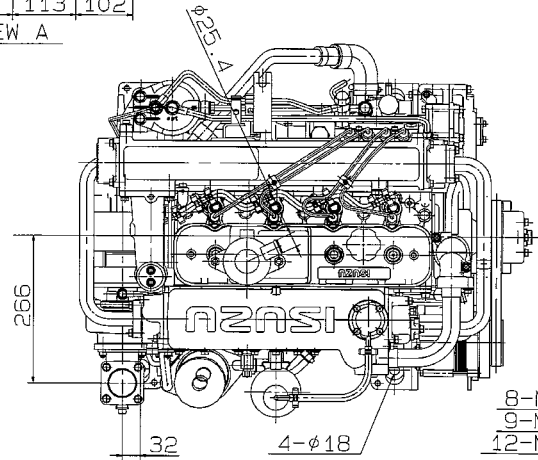
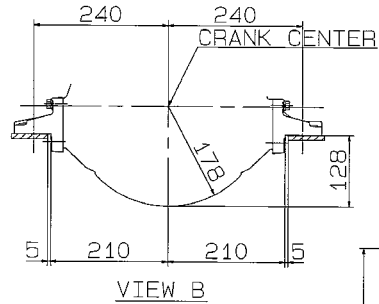
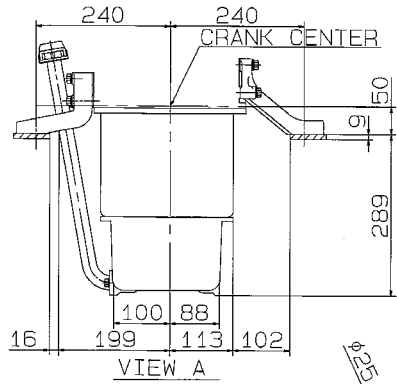

8-M10×1.5 DEEP18  
9-M10×1.5 DEEP18  
12-M10×1.5 DEEP18

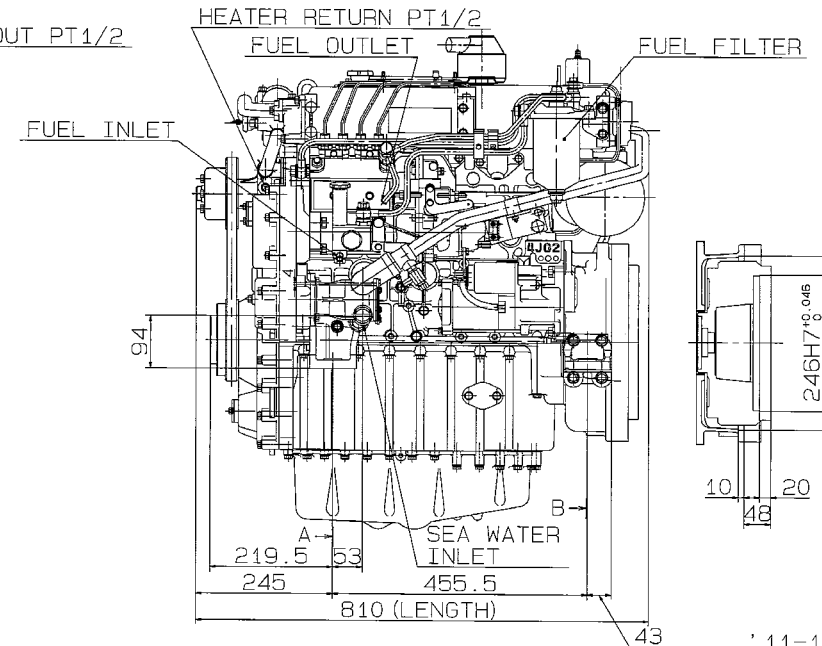
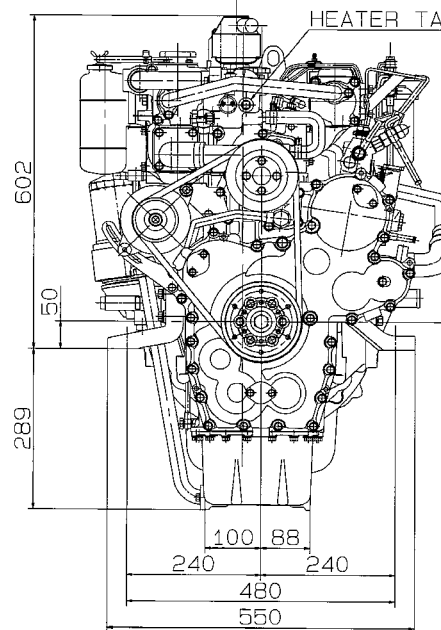
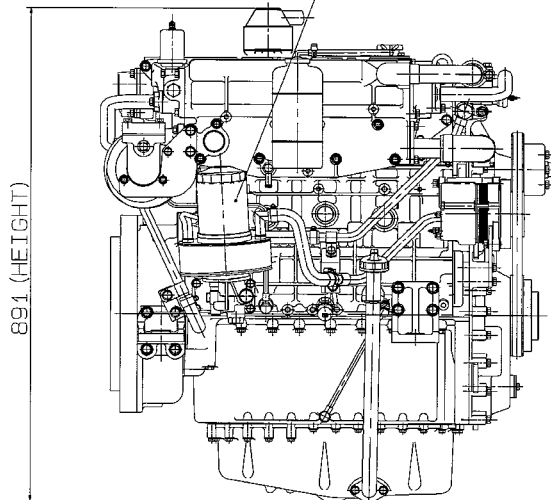
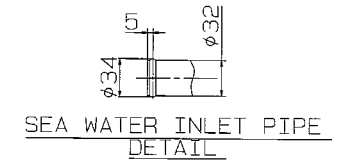
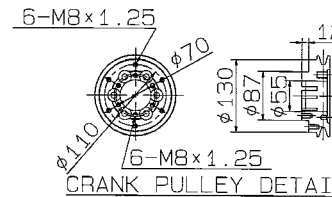
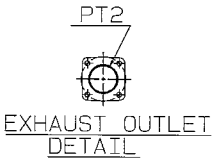
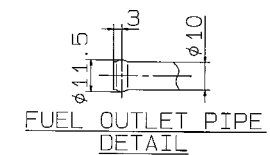
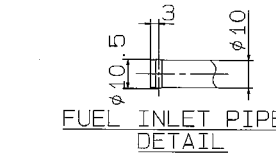
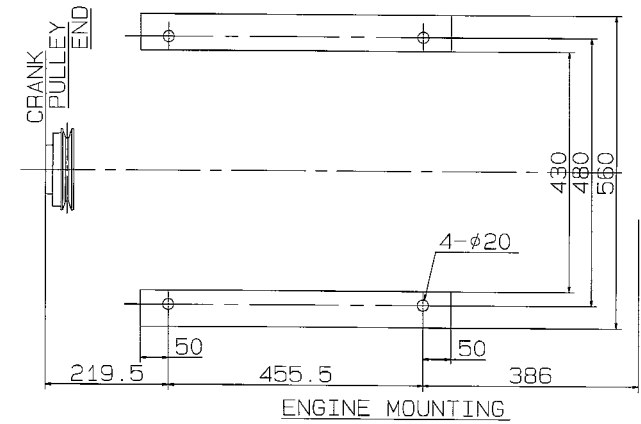
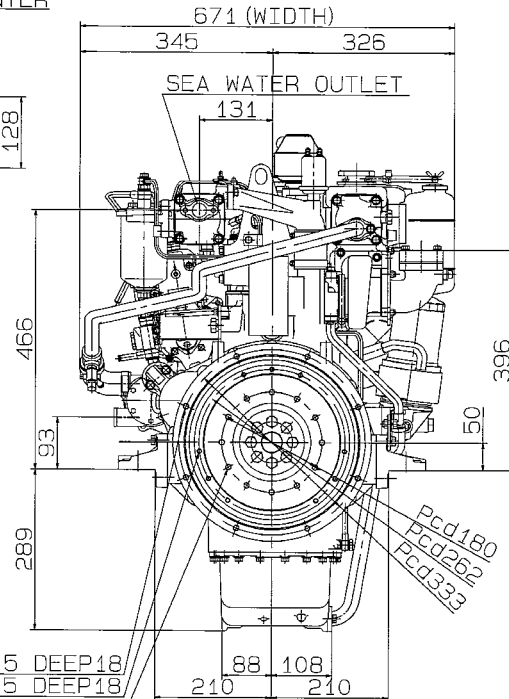

# ISUZU UM4JG1TCX DIESEL ENGINE

MGN30A-2

