

UM4JB1TCX

ISUZU

ISUZU MOTORS ENGINE SALES INC.

UM4JB1TCX

DIMENSIONS (mm)

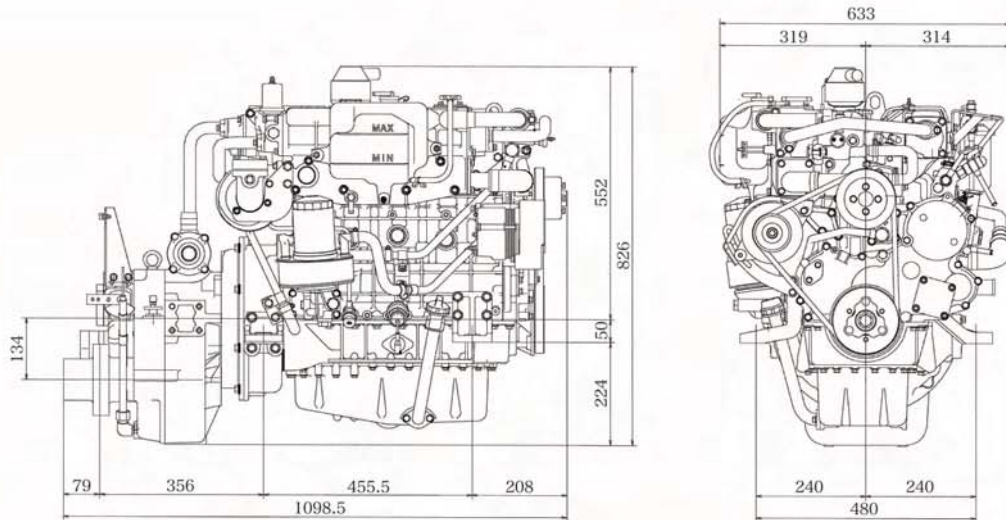

PERFORMANCE CURVES

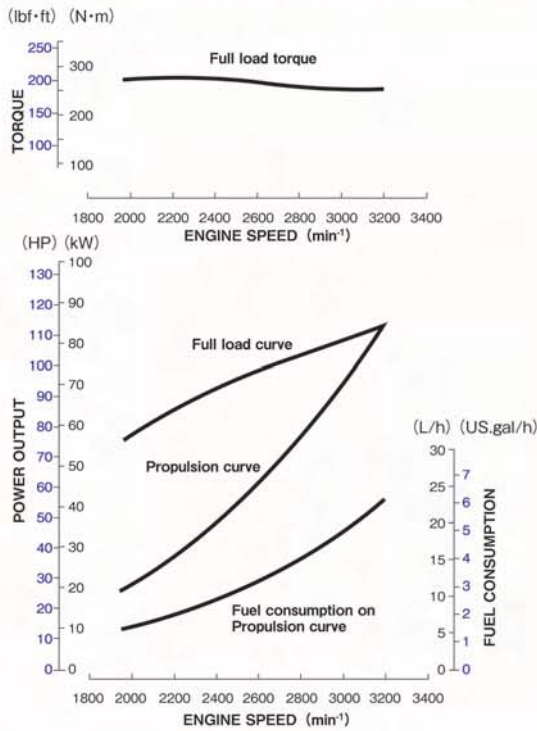

ENGINE SPECIFICATIONS

Configuration	4-cylinder, vertical in-line, 4-cycle diesel engine	
Bore x Stroke	mm (in)	93 x 102 (3.66 x 4.02)
Displacement	Lit. (cid)	2.771 (169)
Rated output	kW(PS)/min ⁻¹	Medium duty
		Light duty
		81 (110) / 3100
		85 (115) / 3200
Application	Commercial use	
Governor type	Mechanical	
Combustion type	Direct injection	
Aspiration	Turbo charged / Intercooler	
Engine weight	kg (lb)	Engine
		with MGN30A
		298 (657)
		424 (934)
Fuel used	Diesel fuel	
Starter	V-kW	24 - 3.2
Alternator	V-A	24 - 30
Lubrication method	Full flow pressure circulation	
Cooling method	Freshwater, full flow pressure circulation (Seawater, indirect)	
Heat exchanger (seawater circulation)	Multi tube type (freshwater→seawater)	
Intercooler	Multi-tube type (seawater circulation)	
Rotation direction	Crankshaft	Right (clockwise) viewed from front of engine
	Propeller shaft	Right (clockwise) viewed from stern
Idling speed	min ⁻¹	500~550
Marine gear	Marine Gear Model	MGN30A
	Clutch type	Wet, Multi-plate hydraulic type
	Reverse type	Constant-mesh type gear
	Reduction ratio	2.04, 2.52, 3.05, 3.44

Specifications subject to change without notice

ACCESSORIES

Standard.....

- Installation kit
- Kingston valve
- Battery relay
- Extension harness (3m)
- Seawater pump impeller *
- Bilge pump
- Control head
- Instrument panel
- Tool kit
- Owner's manual

* spare parts

Option.....

- Extension harness (3m)
- Control cable (4m,6m,10m,12m)
- Stop cable (4m,6m,8m)

ISUZU MOTORS ENGINE SALES INC.

<http://www.isuzumarine.co.jp>

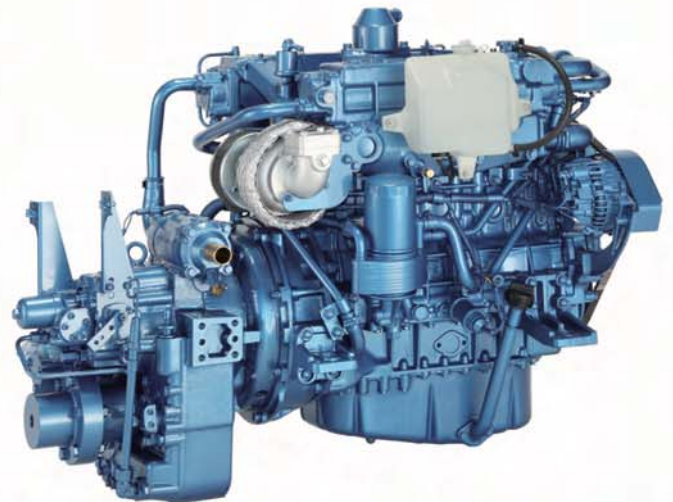

ISUZU UM4JB1TCX DIESEL ENGINE GEAR LESS

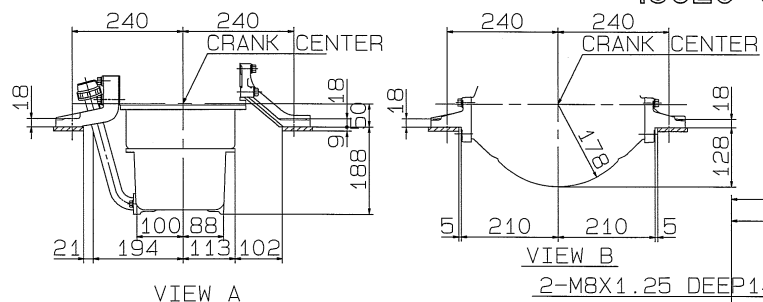

VIEW A

VIEW B

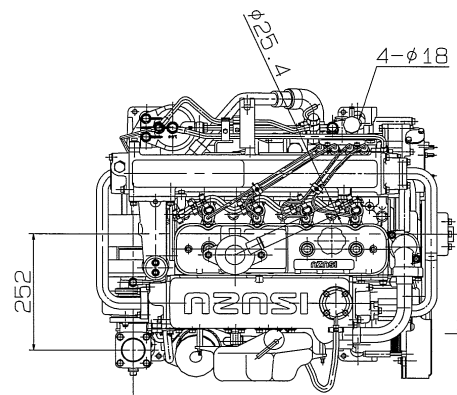

- 8-M10x1.5 DEEP18
- 6-M10x1.5 DEEP18
- 9-M8x1.25 DEEP18
- 12-M10x1.5 DEEP18

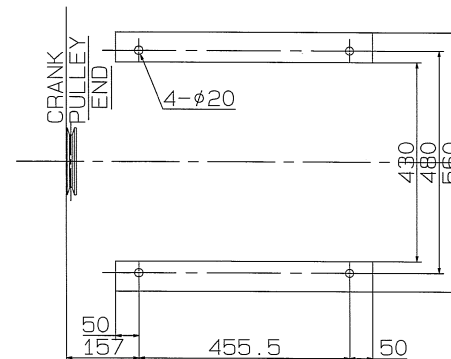
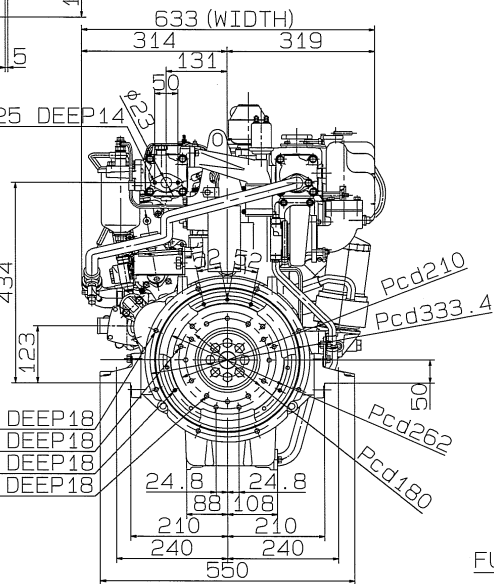

ENGINE MOUNTING

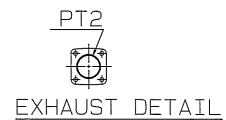

EXHAUST DETAIL

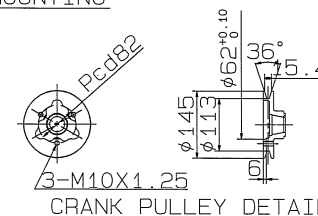

CRANK PULLEY DETAIL

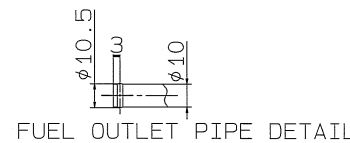

FUEL OUTLET PIPE DETAIL

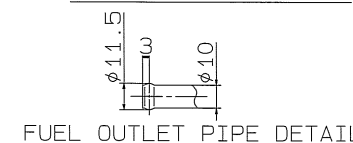

FUEL OUTLET PIPE DETAIL

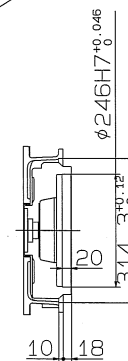
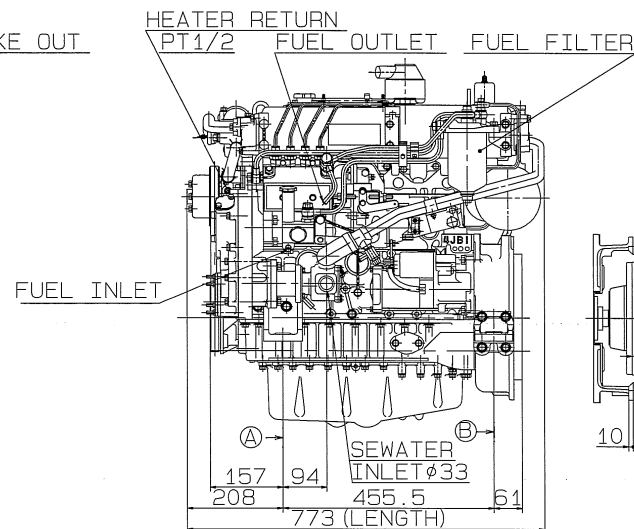
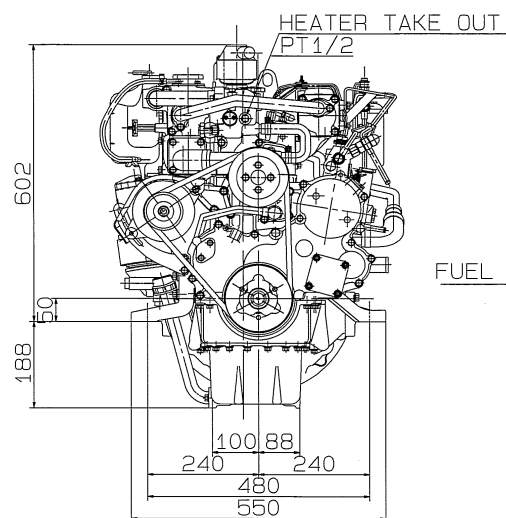
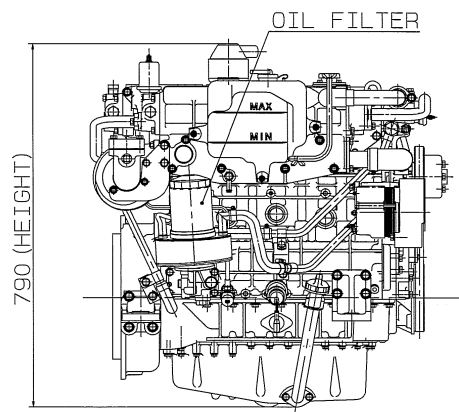

ISUZU UM4JB1TCX DIESEL ENGINE MGN30A-2

