

UM6WG1TC-AB

ISUZU

ISUZU MOTORS ENGINE SALES INC.

UM6WG1TC-AB

DIMENSIONS (mm)

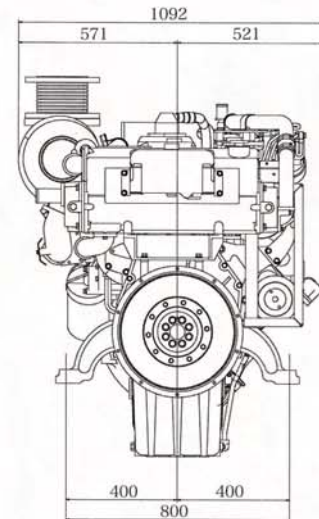
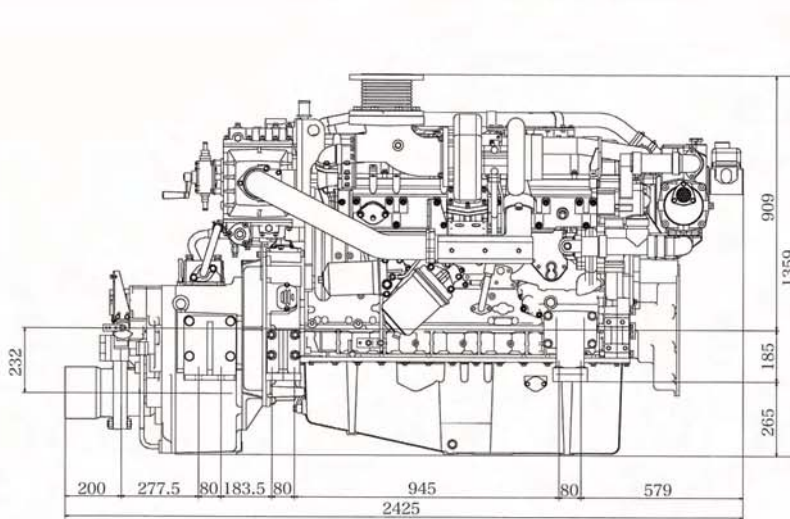

PERFORMANCE CURVES

AB1

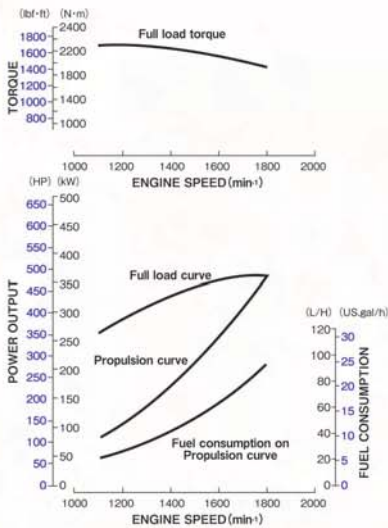

AB2

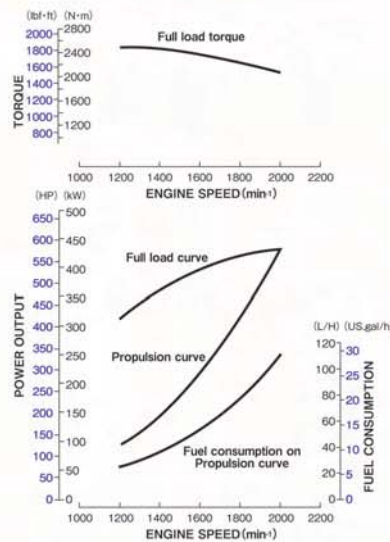

AB3

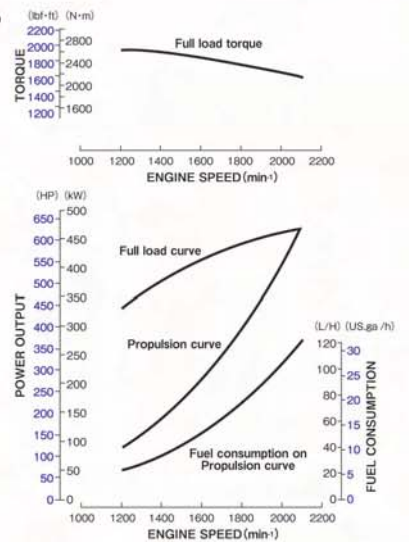

ENGINE SPECIFICATIONS

Configuration	6-cylinder, vertical in-line, 4-cyc e disel engine	
Bore x Stroke	mm (in)	147 x 154 (5.78 x 6.06)
Displacement	Lit. (cid)	15.681 (956)
Rated output *1	kW(PS)/min-1	AB1 377 (512) / 1800
		AB2 447 (608) / 2000
		AB3 485 (659) / 2100
Application	Commercial use	
Governor type	Mechanical	
Combustion type	Direct injection	
Aspiration	Turbo charged / Intercooler	
Exhaust gas status		
Engine weight	kg (lb)	Engine 1,500 (3,307)
		with MGN80B 1,920 (4,233)
Fuel used	Diesel fuel	
Starter	V-kW	24 - 7.4
Alternator	V-A	24 - 50
Lubrication method	Full flow pressure circulation	
Cooling method	Freshwater, full flow pressure c rculati on(Seawater, indirect)	
Heat exchanger (seawater circulation)	Multi tube type (freshwater→seawater)	
Intercooler	Multi-tube type (seawater circulation)	
Rotation direction	Crankshaft	Right (clockwise) viewed from front of engine
	Propeller shaft	Right (clockwise) viewed from stern
Idling speed	min ⁻¹	560~600
Marine gear	Marine Gear Model	MGN80B
	Clutch type	Wet, Multi-plate hydrau ic type
	Reverse type	Constant-mesh type gear
	Reduction ratio	1.68, 2.03, 2.55, 2.96, 3.31, 3.48

ACCESSORIES

Standard.....

- Installation kit
- Oil drain pump
- Battery relay
- Extension harness (5m)
- Seawater pump impeller *
- Bilge pump
- Control head
- Instrument panel
- Blow-by pipe
- V-belt *
- Zinc bars *
- Tool kit
- Owner's manual

* spare parts

Option.....

- Extension harness (5m)
- Control cable (4m,6m,10m,12m)
- Stop cable (4m,6m,8m)

*1: F/W output, AB1:Continuous heavy duty, AB2:Heavy duty, AB3:Medium duty
Specifications subject to change without notice

ISUZU UM6WG1TC-ABH DIESEL ENGINE GEAR LESS

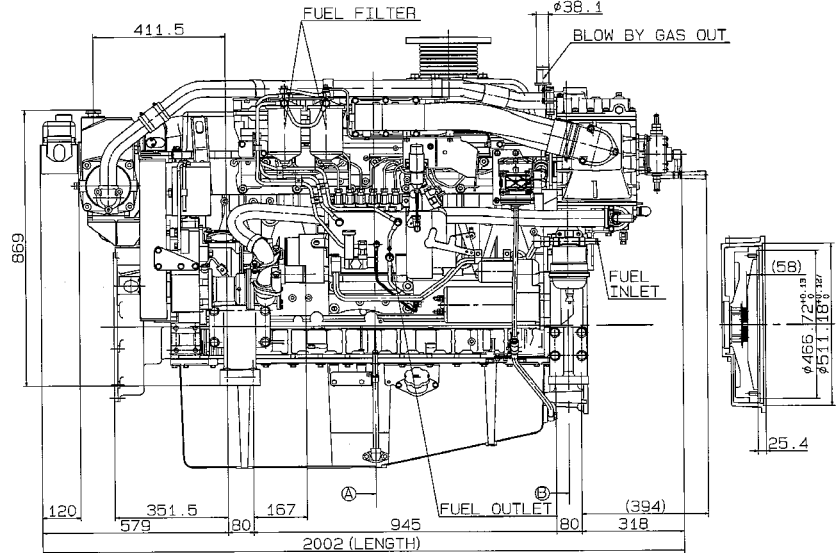
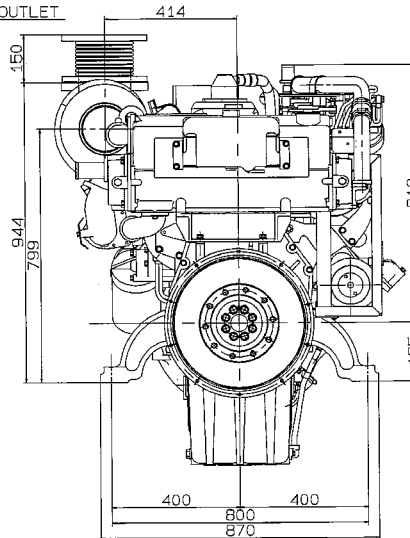
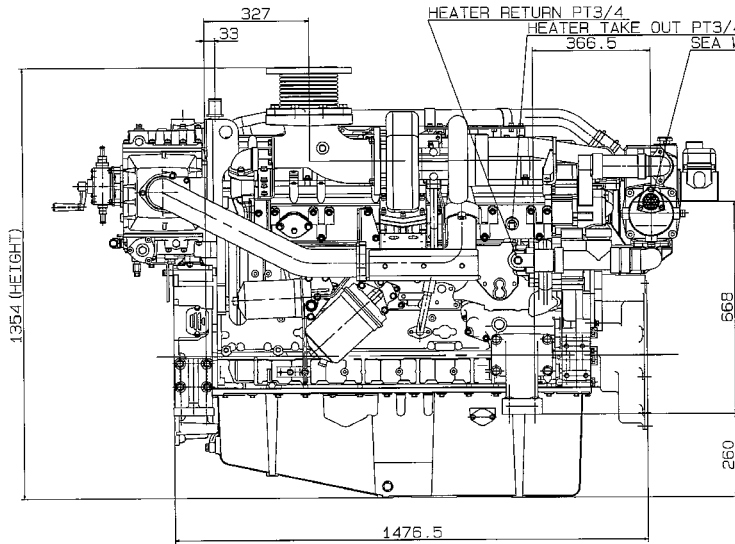
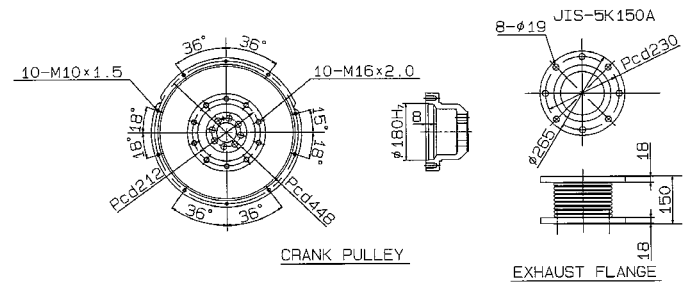
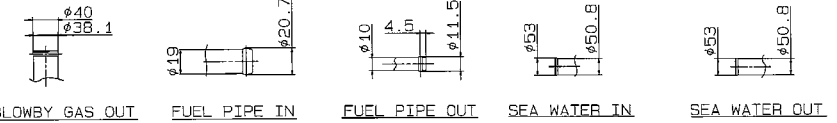
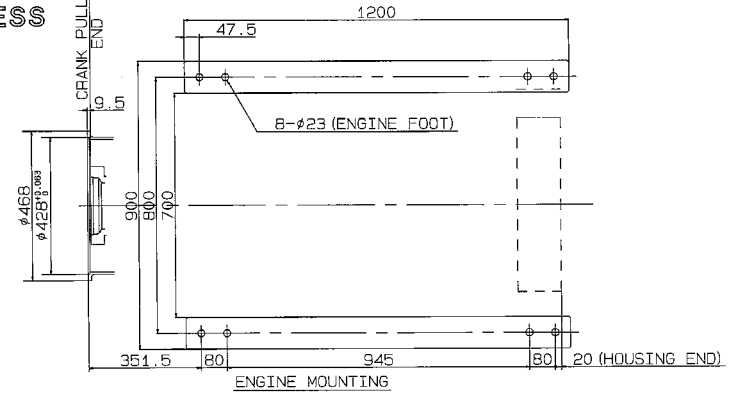
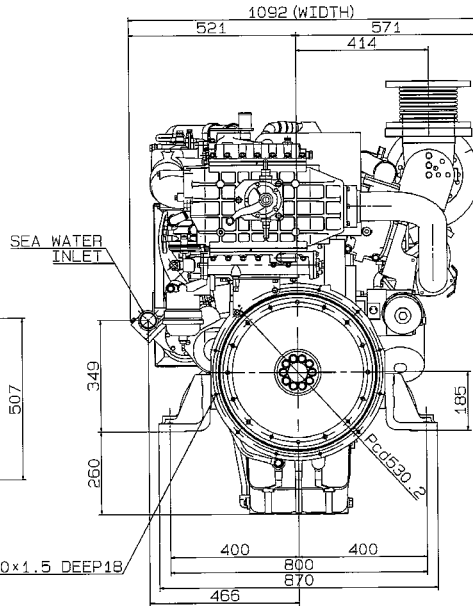
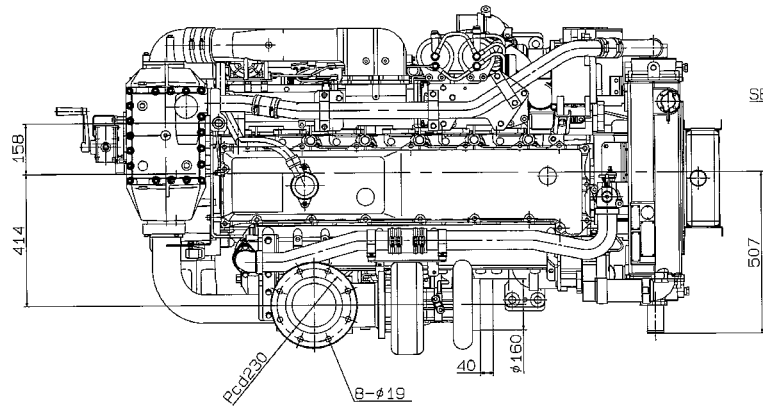
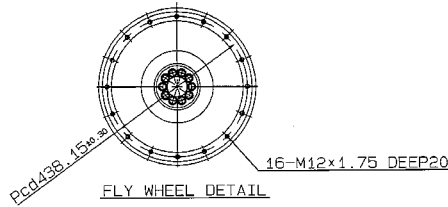
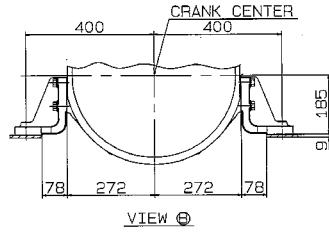
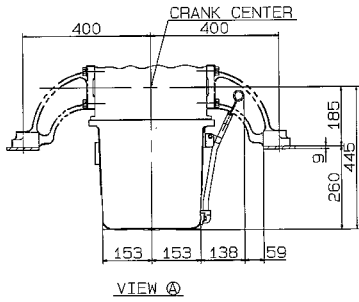

ISUZU UM6WG1TC-ABH DIESEL ENGINE MGN80B

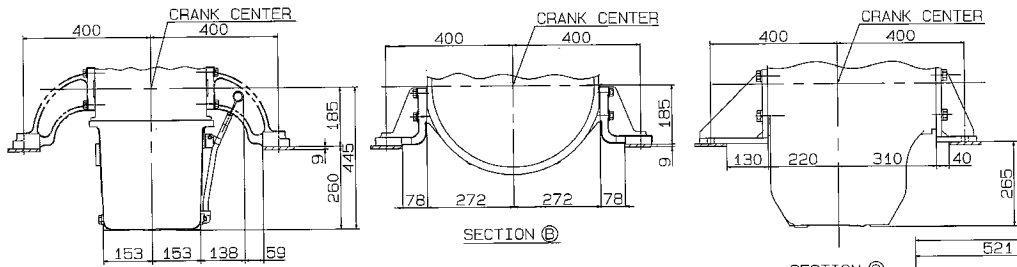

SECTION A

SECTION B

SECTION C

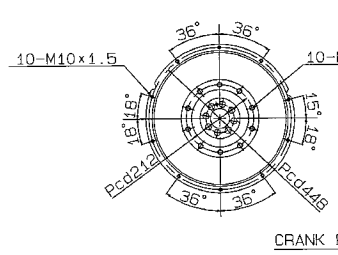
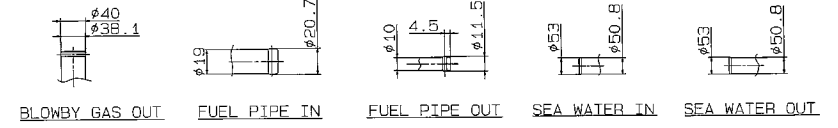
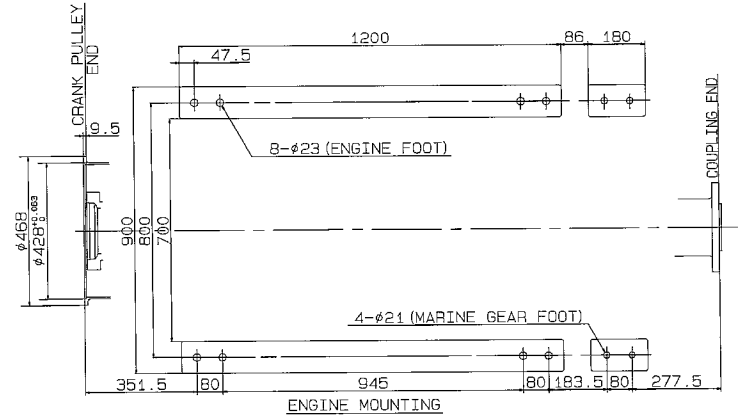
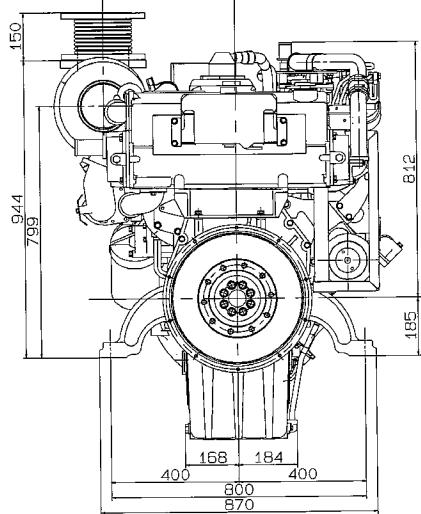
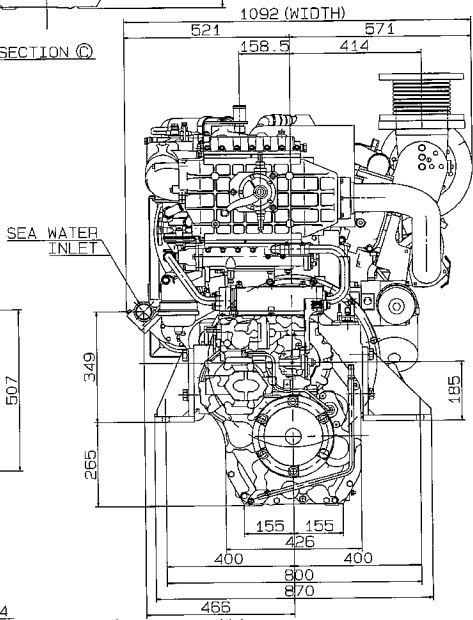
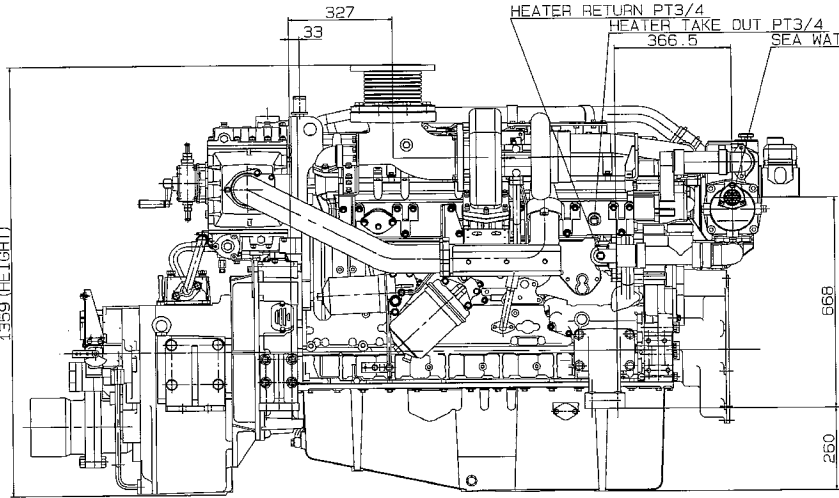
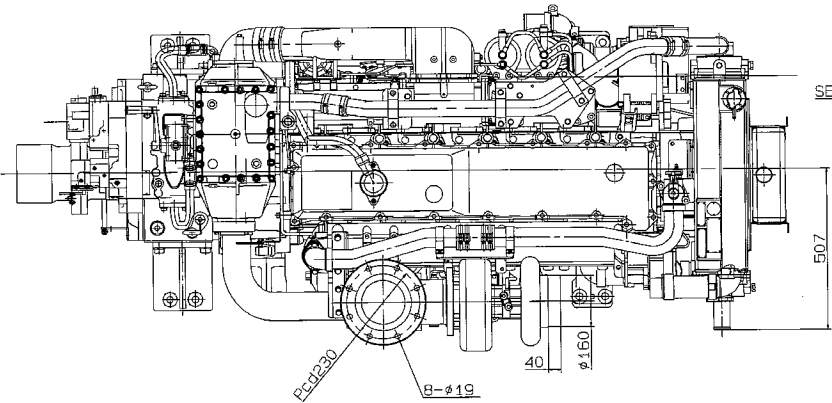

CRANK PULLEY

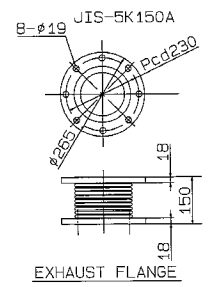

EXHAUST FLANGE

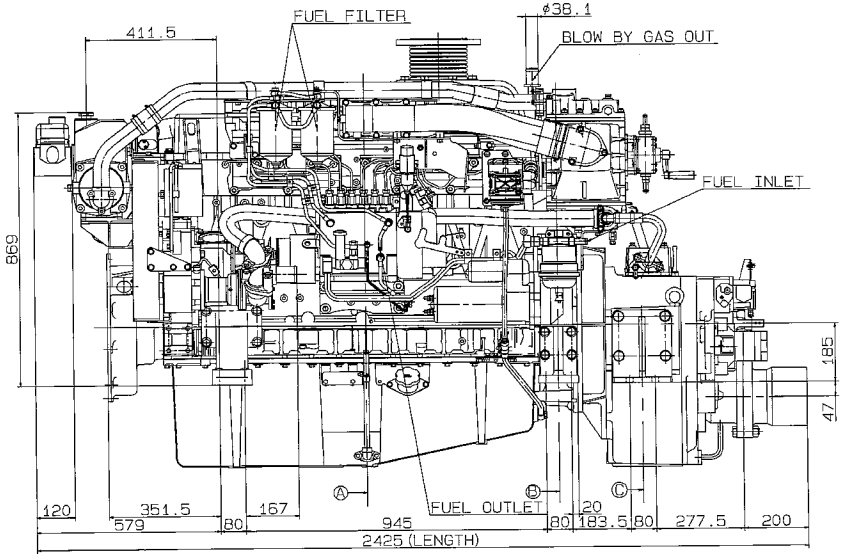

ISUZU UM6WG1TC-ABK DIESEL ENGINE GEAR LESS

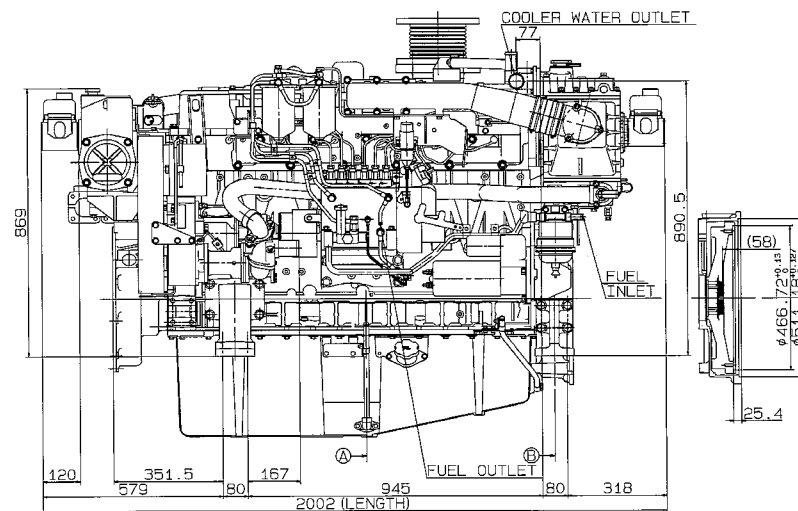
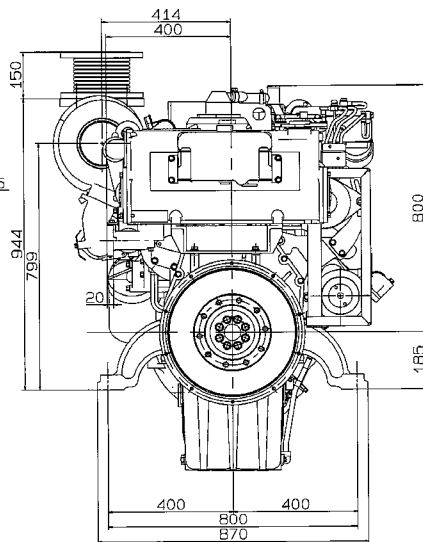
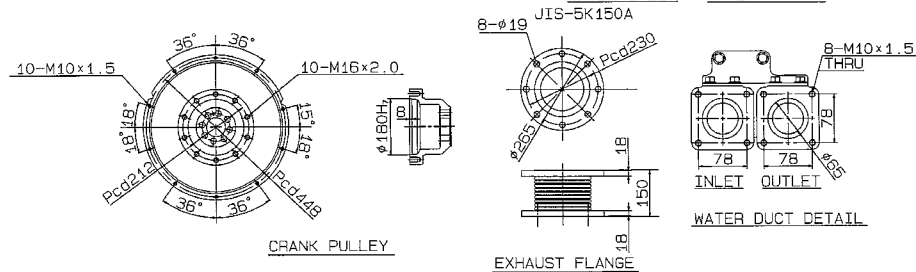
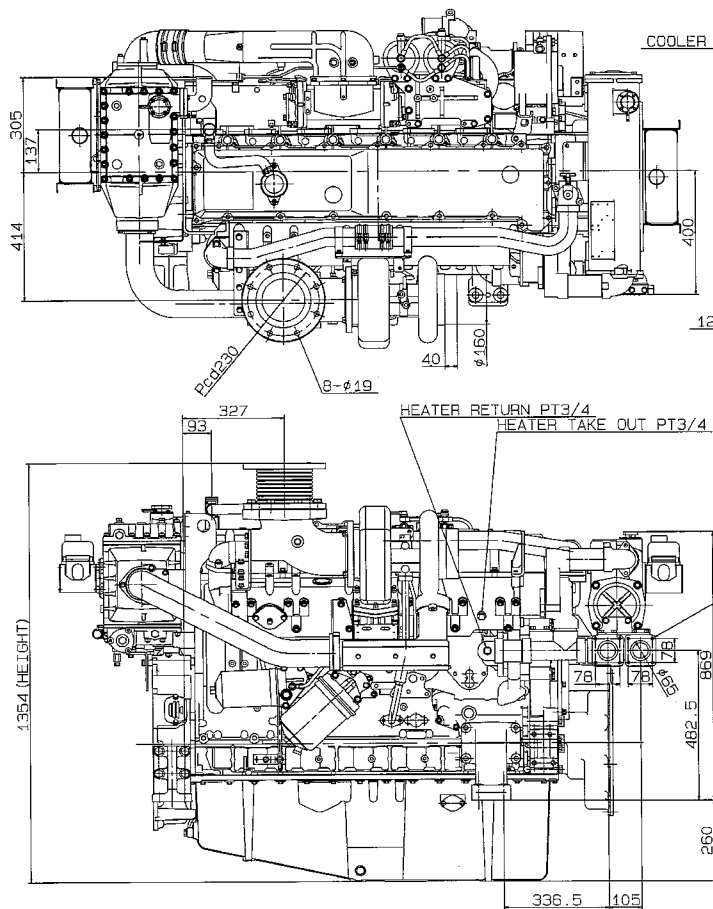
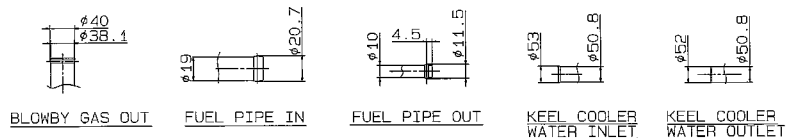
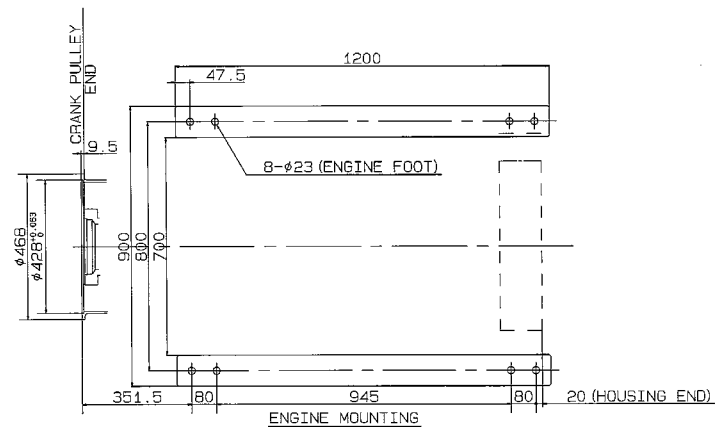
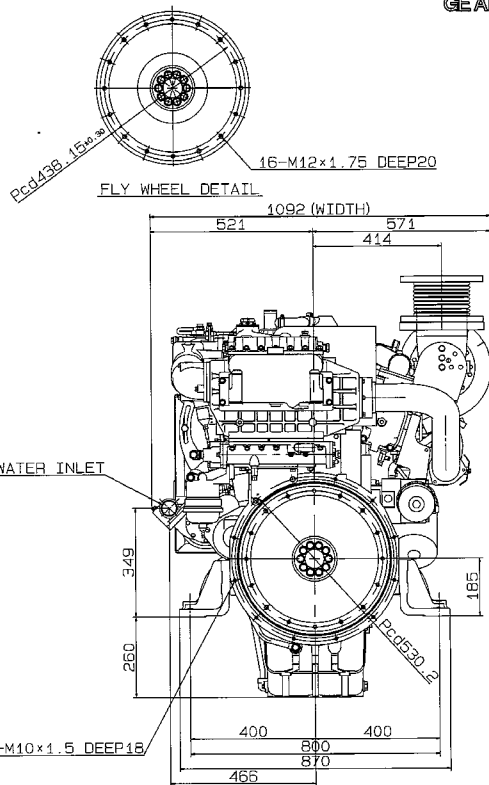
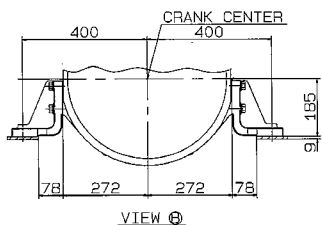
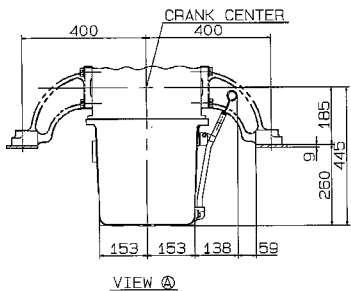

ISUZU UM6WG1TC-ABK DIESEL ENGINE MGN80B

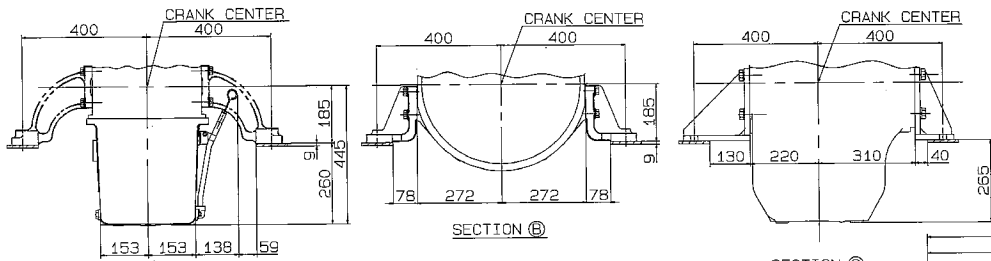

SECTION A

SECTION B

SECTION C

